

LEGEND

- ACC Access panel for filter.
- BLW Dayton paddle-wheel blower (1500CFM @ 6.2" SP).
- CLS Closer for manual doors.
- CDM Common wire in DC input circuit.
- CON Control enclosure with major electrical components.
- DCT 8" wire-mold ducting.
- DIS 25 amp disconnect switch with lockout.
- DIF Diffused light panel.
- DR1 3' 0" X 7' 0" aluminum-frame entry door (dirty side).
- DR2 3' 0" X 7' 0" aluminum-frame exit door (clean side).
- EMO Emergency-off switch with N.C. contact.
- FLT 24" X 24" X 12" HEPA filter (>99.97% @ .3).
- FLX Flexible conduit for electrical power line.
- GLA 1/4" clear tempered glass for storefront-type doors.
- GRL 24" X 12" X 1" 30% efficiency prefilter.
- HNG Commercial ball-bearing door hinges.
- ISD Neoprene rubber isolators.
- JCT NEMA 1 Junction box
- LGT 4' double-tube fluorescent fixture (.76A @ 120V).
- LK1 Lock for door 1 (.250A @ 24VDC).
- LK2 Lock for door 2 (.250A @ 24VDC).
- MEC Mechanical wall equipment housing.
- MOT 5HP 3-phase motor for main blower
- MSC Motor starter coil (60mA @ 120V).
- NOZ .875" adjustable nozzle jets (32 in walls, 4 in ceiling).
- PEN Penetration for lag bolts.
- PL1 Plenum for nozzle jets.
- PL2 Plenum for return air.
- PLC Programmable controller (20mA @ 120V).
- PDD 1/2" steel pod for lag bolts.
- PRE 24" X 12" X 1" 30% efficiency prefilter.
- RET Return air ductway.
- RS1 Reed switch for door 1.
- RS2 Reed switch for door 2.
- STP Aluminum doorstop with gasket seal.
- SUP Supply air ductway.
- SWP Drag sweep to seal door bottom.

EXIT ELEVATION

ENTRY ELEVATION

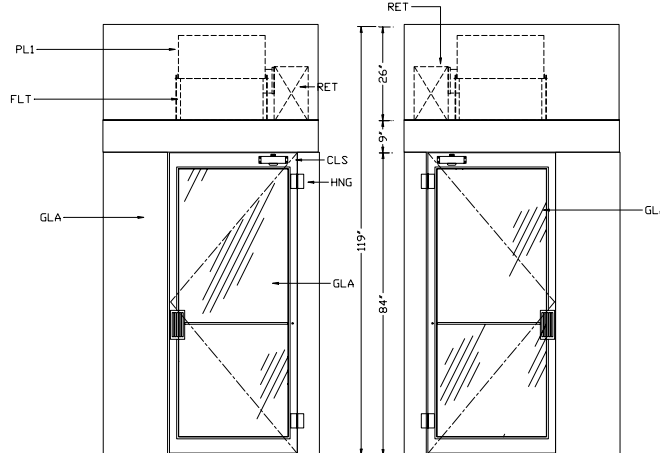

SIDE ELEVATION

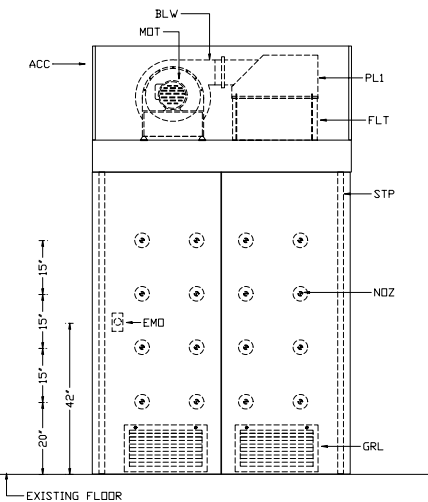

NOTES:

1. THE AIR SHOWER IS CONSTRUCTED OF A WOOD CORE WITH A WHITE PLASTIC LAMINATE FINISH. ALL CUT OUTS ARE SEALED.
2. THE POWER PANEL IS PRE-WIRED AT THE FACTORY AND IS TESTED. THE PANEL IS CONNECTED TO 8 FEET OF SEAL TIGHT FLEX. THE PANEL IS TO MOUNTED TO AN ADJACENT WALL DURING INSTALLATION.

CONTRACT NO.		COMPANY		
DRAWN BY	HSD	DATE	ASPT Inc.	
CHECKED BY		TITLE	SD6072 AIR SHOWER	
DESIGNED BY		SIZE	FSCM NO.	DWG NO. / FILE NAME
DESIGN ACTIVITY		A		
CUSTOMER		SCALE	DATE	SHEET
		1" = 2'-0"		1 of 1